

**JOHNSON**  
Components™

**SMK (2.92mm) Connectors**

**Emerson Network Power  
Connectivity Solutions**

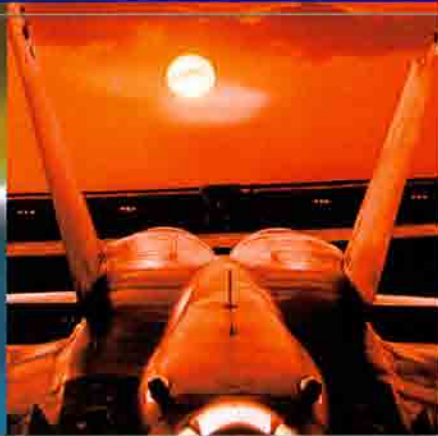

  
**EMERSON™**  
Network Power

**EMERSON. CONSIDER IT SOLVED.™**

## Johnson Components™ SMK (2.92mm) Connectors

The Johnson Components™ SMK Connector provides an excellent solution for demanding applications requiring high frequency transmission. Although similar to the SMA interface, a smaller internal body diameter (2.92mm) and air dielectric provide a higher cutoff frequency and other key advantages:

- Precision manufacturing allows superior electrical performance to 40 GHz.
- Female contacts have a unique three-slot construction, which enhances connectivity by creating a more rugged connector while reducing the chance of intermittent connections.
- Precise assembly tooling assures excellent, repeatable contact and support bead location on cabled connectors.
- Connector mating interface per MIL-STD-348
- Mating interface control provides consistent electrical performance.
- The plug connector VSWR is 1.20 Max to 40 GHz and a 12 inch SMK plug to plug cable assembly performs better than 1.35 VSWR to 40 GHz.
- The Field Replaceable Jacks are teamed with a high quality hermetic seal feed thru for use in sealed circuit modules.
- The SMK plug interface employs more precise dimensions than an SMA and uses a shorter snub nose male pin such that the connector bodies align before the contacts engage.



### MATERIAL SPECIFICATIONS

**Bodies:** Stainless steel per QQ-B-626, gold plated\* per MIL-G-45204 .00005" min. or passivated per MIL-F-14072 B (EL) 300

**Contacts:**

Female - beryllium copper per QQ-C-530, gold plated per MIL-G-45204 .00005" min.

**Contact Support Beads:** PTFE fluorocarbon per ASTM D 1710 and ASTM D 1457 or modified PPE resin

**Seal Rings:** Silicone rubber per ZZ-R-765

\* All gold plated parts include a .00005" min. nickel underplate barrier layer.

### MECHANICAL RATINGS

**Engagement Design:** MIL-STD-348, Series SMK (2.92mm)

**Engagement/Disengagement Force:** 2 inch-pounds maximum

**Mating Torque:** 7 to 10 inch-pounds

**Coupling Proof Torque:** 15 inch-pounds minimum

**Coupling Nut Retention:** 60 pounds minimum

**Contact Retention:** 6 lbs. minimum axial force (captivated contacts)

**Cable Retention:** Axial Force\*(lbs) Torque (in-oz)

.086 semi-rigid .....	30	16
.141 semi-rigid .....	60	55

\*Or cable breaking strength whichever is less.

**Durability:** 500 cycles minimum

**Notes:**

1. ID of contact shall meet VSWR and connectivity requirements when mated with dia. .0355-.0365 male pin.

### Mating Engagement for SMK (2.92mm) Series per MIL-STD-348

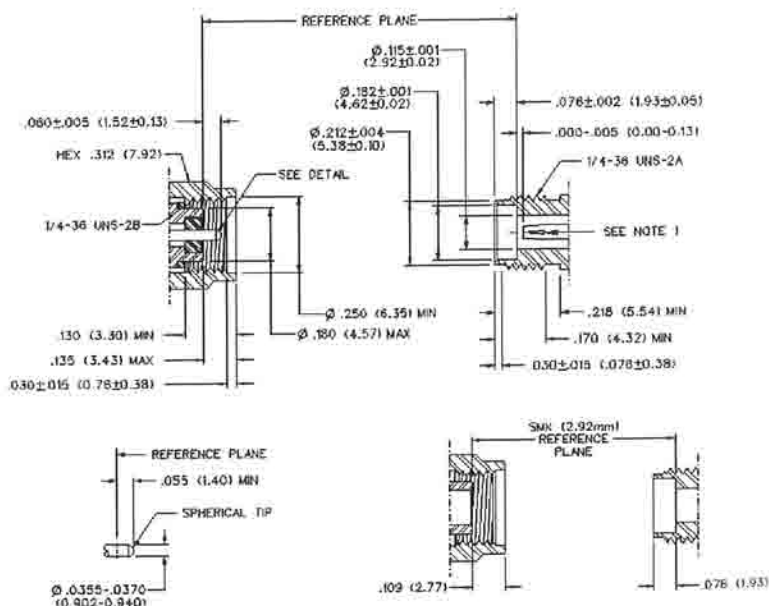



## ELECTRICAL RATINGS

**Impedance:** 50 ohms

**Frequency Range:** 0-40 GHz

**VSWR:** (f = GHz)

Semi-rigid straight cabled connectors and adapters ..... 1.20 Max

Field replaceable (see typical return loss graph) ..... N/A

**Working Voltage:** (Vrms maximum)

**Connectors for Cable Type**

**Sea Level 70K Feet**

.086 semi-rigid and field replaceable ..... 335 85

.141 semi-rigid and adapters ..... 500 125

**Dielectric Withstanding Voltage:** (VRMS minimum at sea level)

.086 semi-rigid and field replaceable ..... 1000

.141 semi-rigid and adapters ..... 1500

**Corona Level:** (Volts minimum at 70,000 feet)

.086 semi-rigid and field replaceable ..... 250

.141 semi-rigid and adapters ..... 375

**Insertion Loss:** (dB maximum)

Adapters .....  $0.06 \sqrt{f(\text{GHz})}$ , tested at 6 GHz

Straight semi-rigid cable connectors .....  $0.03 \sqrt{f(\text{GHz})}$ , tested at 10 GHz

**Insulation Resistance:** 5000 megohms minimum

**Contact Resistance:** (milliohms maximum) **Initial After Environmental**

Center contact straight cabled connectors ... 3.0\* 4.0

Center contact adapters ..... 4.0 6.0

Field replaceable connectors ..... 6.0 8.0

Outer contact (all connectors) ..... 2.0 N/A

Body to cable (gold plated connectors) ..... 0.5 N/A

Body to cable (passivated connectors) ..... 5.0 N/A

**RF Leakage:** (dB minimum, tested at 2.5 GHz) ..... -90dB

**RF High Potential Withstanding Voltage:** (Vrms minimum, tested at 4 and 7 MHz)\*

.086 semi-rigid and field replaceable ..... 670

.141 semi-rigid and adapters ..... 1000

## ENVIRONMENTAL RATINGS

(Meets or exceeds the applicable paragraph of MIL-C-39012)

**Temperature Range:** - 65°C to + 165°C

**Thermal Shock:** MIL-STD-202, Method 107, Condition B

**Corrosion:** MIL-STD-202, Method 101, Condition B

**Shock:** MIL-STD-202, Method 213, Condition I

**Vibration:** MIL-STD-202, Method 204, Condition D

**Moisture Resistance:** MIL-STD-202, Method 106

## FIELD REPLACEABLE APPLICATION NOTES

The field replaceable connectors manufactured by Johnson Components™, are easy to install and replace. The hermetic seal is mounted into the circuit module wall and the connector can be removed and replaced without destroying the hermeticity of the circuit housing.

The field replaceable connector creates a transition from microstrip circuitry to a coaxial transmission line. The SMK (2.92mm) seal pin diameter is .012 (.030) to minimize the capacitive effects on the circuit trace. For optimum electrical performance, the transition from the hermetic seal to the microstrip trace must be properly compensated. Compensation involves adjusting the microstrip trace width to minimize any impedance discontinuities found in the transition area.

The plot shown below is representative of the typical return loss of a Johnson Components™ field replaceable SMK connector. To produce the data shown below, a test fixture is created using the Johnson Components™ SMK hermetic seal. The fixture consists of a suitably thick spacer plate with the hermetic seal mounted flush to both surfaces. Two connectors are mounted back to back around the fixture and the VSWR of this test assembly is measured. The calculated return loss trace shown is equivalent to the square root of the measured VSWR of the test assembly. Since the connectors tested are of identical design, it can be stated with fair accuracy that the calculated data shown represents the response of a single field replaceable connector and its transition to the hermetic seal.

Although Johnson Components™ does not publish a VSWR specification for field replaceable connectors, typical connector return loss can be expected to be less than -20 dB through 40 GHz. A VSWR specification is not stated because an industry standard method for testing field replaceable connectors does not exist. The actual performance of the connector is dependent upon the following:

1. For optimum electrical performance, Johnson Components™ recommends the use of our standard 142-1000-033 hermetic seal with a pin diameter of .0120 (0.305) +/- .0005 (0.013).
2. It is recommended that the hermetic seal be mounted flush with the circuit housing. Tolerance variations between the hermetic seal and machined housing do not always guarantee an optimum transition to the connector. Some manufacturers recommend an additional counterbore in the circuit housing to accommodate a solder washer during installation of the seal. Johnson Components™ does not recommend this type of installation because if the counterbore is not completely filled with solder, electrical discontinuities may be created.
3. The transition between the hermetic seal pin and the microstrip trace will effect electrical performance, as stated above. Several different methods of hermetic seal mounting and seal pin to microstrip trace attachment are used in the industry.

## FIELD REPLACEABLE TEST ASSEMBLY

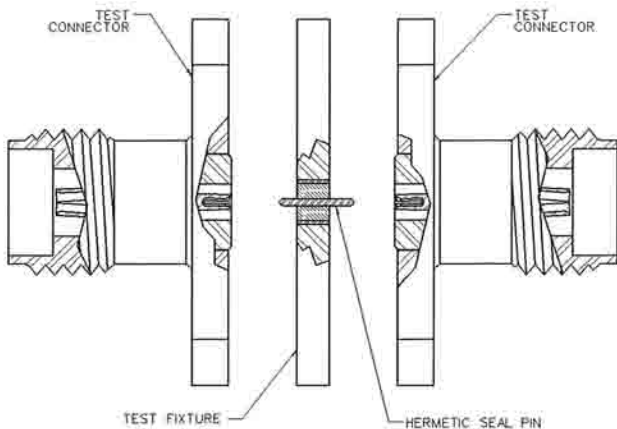

## TYPICAL RETURN LOSS

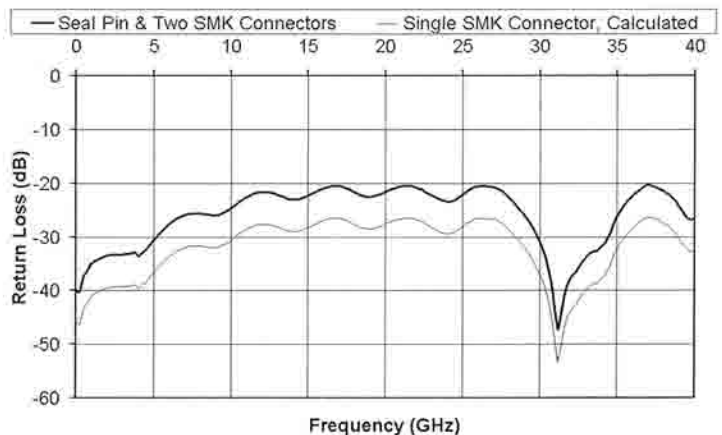

# SMK - 50 Ohm Connectors (2.92mm)

INCHES (MILLIMETERS) • CUSTOMER DRAWINGS AVAILABLE UPON REQUEST

## Straight Solder Type Plug - with contact, slide-on nut

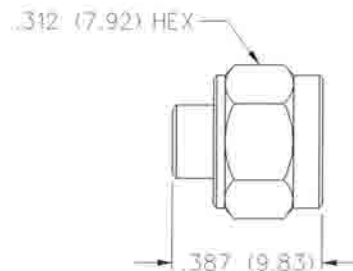

CABLE TYPE	GOLD PLATED	PASSIVATED*
.086 Semi-Rigid	145-0693-001	145-0693-002
.141 Semi-Rigid	145-0694-001	145-0694-002

Assembly instructions on back page.  
\* Passivated coupling nut, gold plated body.

## 2-Hole Flange Mount Jack Receptacle

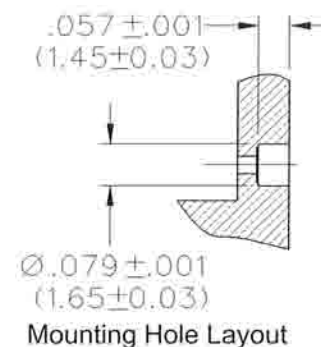
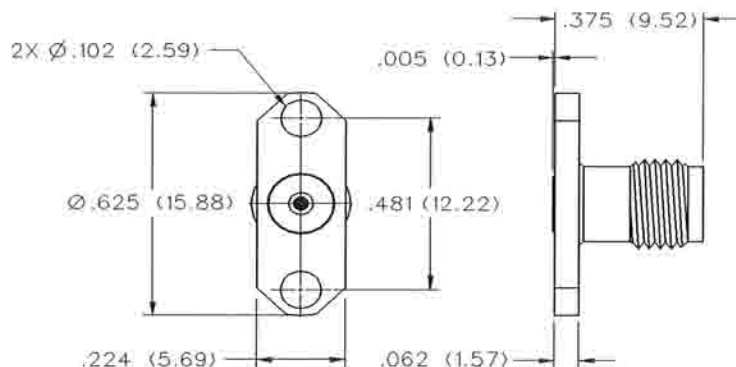

ACCEPTS PIN SIZE	GOLD PLATED	PASSIVATED
.0120 +/- .0005 (0.305 +/- .013)	145-0701-601	145-0701-602

## 4-Hole Flange Mount Jack Receptacle

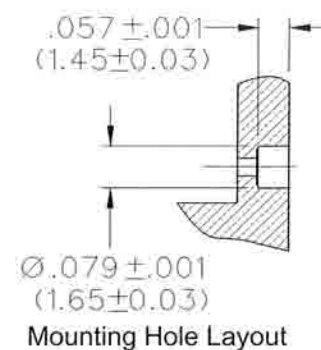
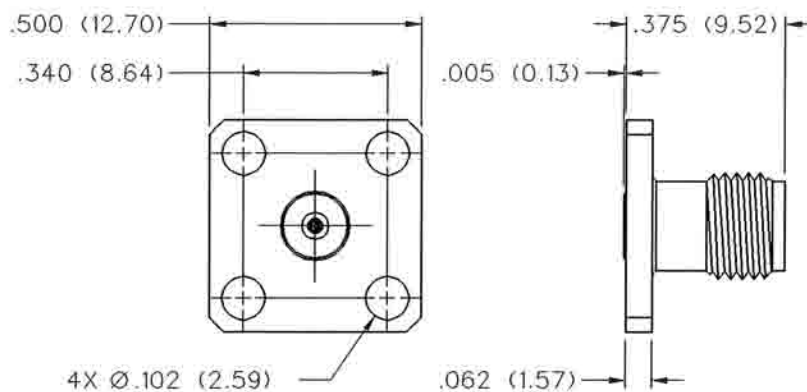

ACCEPTS PIN SIZE	GOLD PLATED	PASSIVATED
.0120 +/- .0005 (0.305 +/- .013)	145-0701-611	145-0701-612



## Jack Receptacle - Thread Mount Field Replaceable

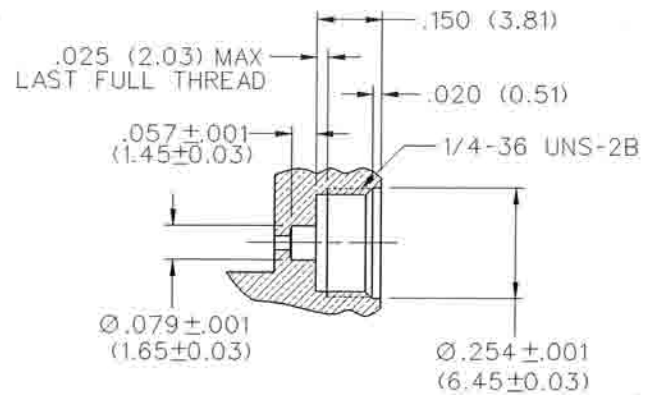
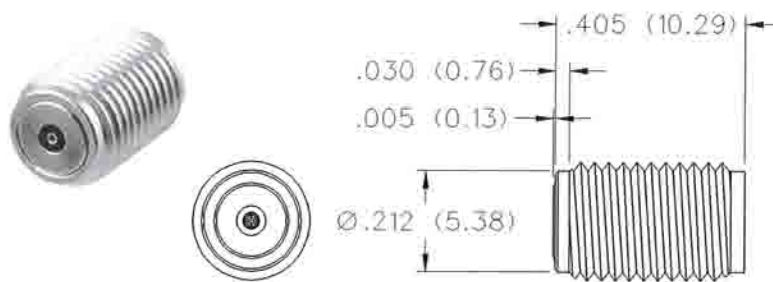

Mounting Hole Layout

ACCEPTS PIN SIZE	GOLD PLATED	PASSIVATED
.0120 +/- .0005 (0.305 +/- .013)	145-0701-001	145-0701-002

## Hermetic Seal Feedthru

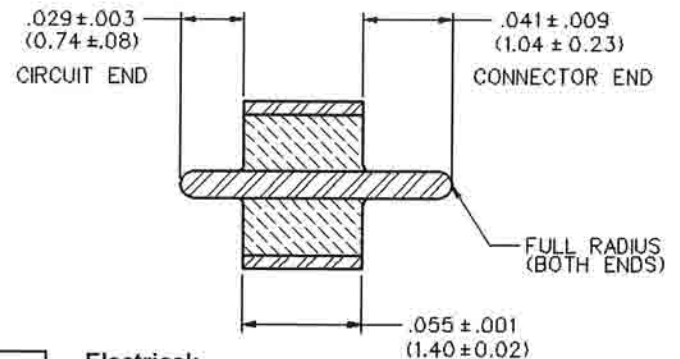
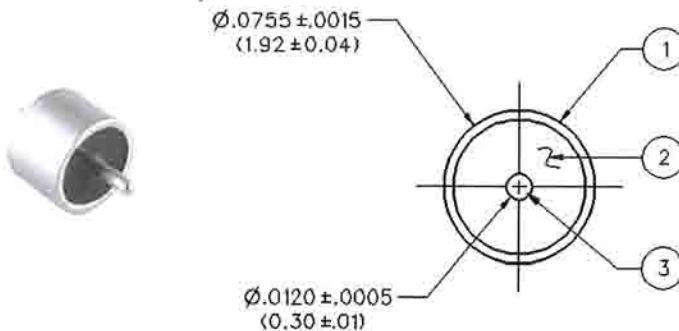

PART NUMBER	ITEM 1 OUTER RING	ITEM 2 INSULATOR	ITEM 3 PIN
142-1000-033	Kovar Gold pl .00005 min. over Nickel pl .00005 min.	Glass Corning 7070 or equivalent	Kovar Gold pl .00005 min. over Nickel pl .00005 min.

**Electrical:**

Impedance: 50 Ohms  
 Frequency Range: DC to 40 GHz  
 VSWR: Dependent upon application  
 Working Voltage: 250 Vrms max at sea level  
 Dielectric Withstanding Voltage: 500 Vrms min. at sea level  
 Insulation Resistance: 5000 Megohm min.  
 Insertion Loss: 0.2 dB max at 40 GHz

**Environmental:**

Hermeticity:  $1 \times 10^{-8}$  cc/sec at one atmosphere  
 Solderability: MIL-STD-202, Method 209  
 Operating Temperature: -55° C to 165° C

**Notes:**

1. The hermetic seal should be mounted as flush as possible with the housing. Excessive recession will create a high impedance air gap between connection and housing which degrades electrical performance.
2. The use of an additional counterbore to accommodate a solder ring for seal mounting is not recommended. A slight chamfer may be used if care is taken to completely fill the area with solder - **avoid air gaps.**

## Jack to Jack In-Series Adapter



<b>GOLD PLATED</b>
145-0901-801

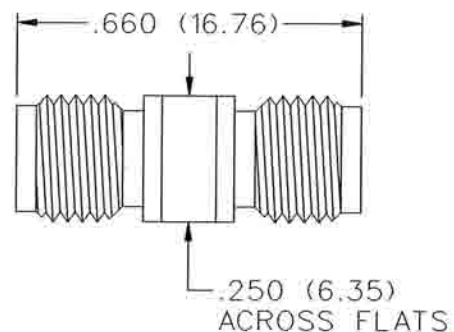

# SMK - 50 Ohm Connectors (2.92mm)

INCHES (MILLIMETERS) • CUSTOMER DRAWINGS AVAILABLE UPON REQUEST

## Plug to Plug In-Series Adapter



<b>GOLD PLATED</b>
145-0901-811

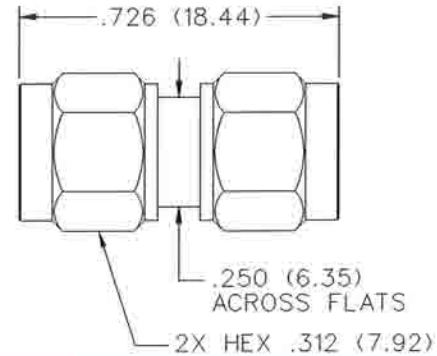

## Plug to Jack In-Series Adapter



<b>GOLD PLATED</b>
145-0901-821

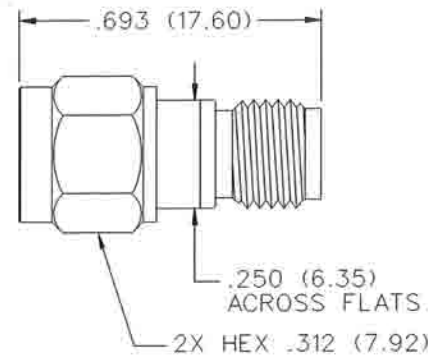

## SMK (2.92mm) Tools

Accurate assembly of the SMK Cabled Connectors is obtained with the tools listed below. Industry standard devices are used if possible for customer convenience and tool compatibility.

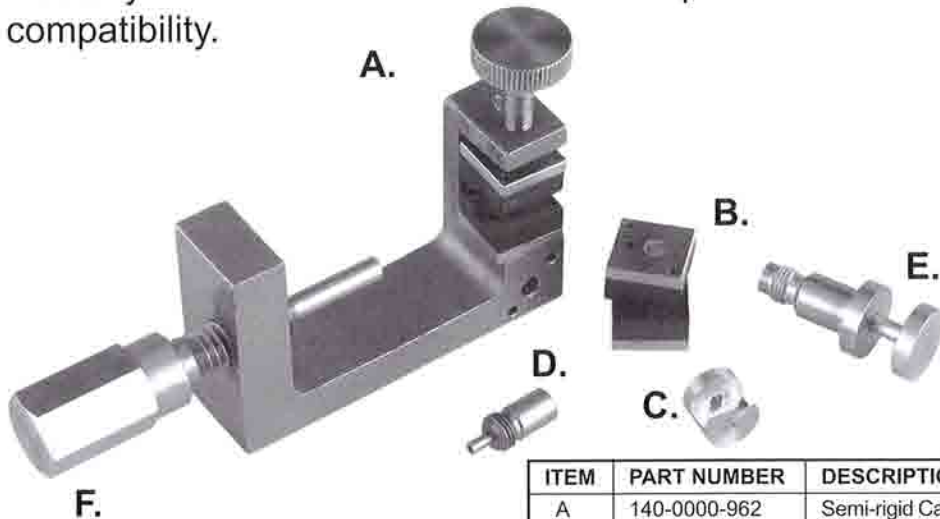

ITEM	PART NUMBER	DESCRIPTION
A	140-0000-962	Semi-rigid Cable Vise (does not include inserts (B) or Vise Stop (F))
B	140-0000-964 140-0000-965	Cable Clamp Inserts, .086 Semi-rigid Cable Clamp Inserts, .141 Semi-rigid
C	140-0000-960 140-0000-961	Contact Soldering Tool, .086 Plug Contact Soldering Tool, .141 Plug
D	140-0000-958 140-0000-959	Body Soldering Tool, .086 Plug Body Soldering Tool, .141 Plug
E	140-0000-957	Bead Assembly Tool, Semi-rigid Plugs, All Cables
F	140-0000-968	Vise Stop, (2.92mm)



## SMK Solder Type Straight Plugs For Semi-rigid Cable

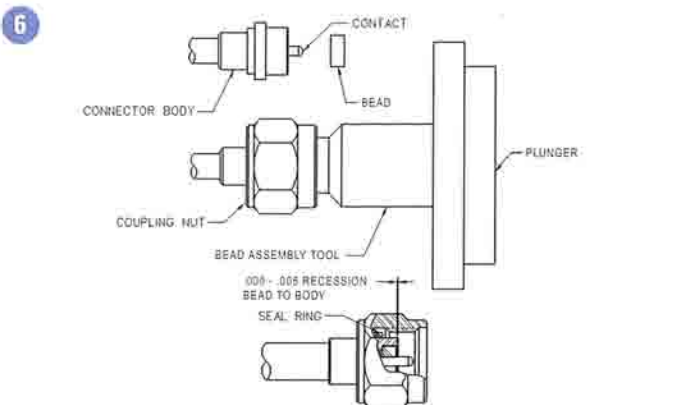
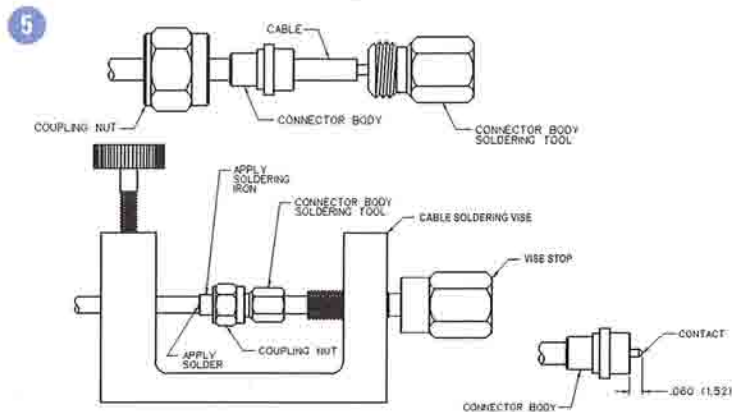
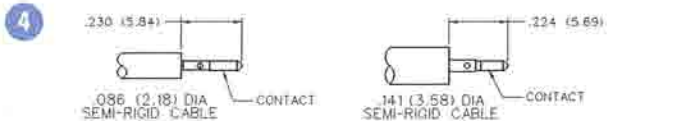
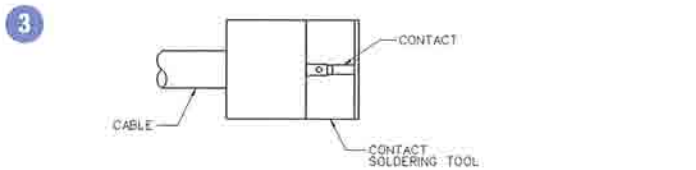
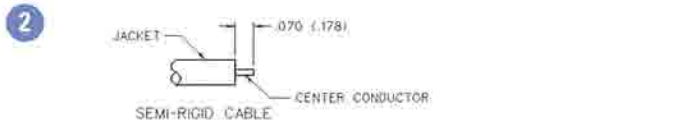
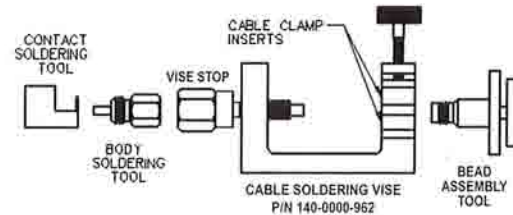
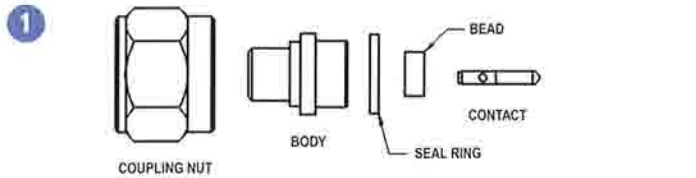

- 1 Identify connector parts (5 piece parts) and tools (5 tools.)
- 2 Strip cable jacket and dielectric to dimension shown.
- 3 Place center contact onto center conductor. Slide contact soldering tool onto contact. Clamp the cable contact and tool into cable soldering vise and solder contact to center conductor. **High temperature** solder, such as 95/5 Sn/Ag is recommended so that contact solder joint remains stable during body soldering operation. Solder paste is recommended for the contact solder joint to minimize excess solder. The assembled dimension should be as shown.
- 4 Remove excess solder from contact with a sharp blade and clean contact. Check for presence of excess solder by sliding body soldering tool over the contact. Remove soldering tool.
- 5 Place connector nut and body on cable. Place connector body soldering tool over contact and thread the coupling nut and connector body firmly to the tool. Place cable subassembly into cable soldering vise. Clamp cable and soldering tool securely to insure the cable dielectric expansion will not disturb the cable in the vise during soldering. Place hot soldering iron on the connector body sleeve and apply solder from the opposite side. A **low temp** solder, such as 60/40 Sn/Pb is recommended for the body solder joint. Allow the soldered joint to cool and remove from fixture. Check contact location to the body. The best electrical results are achieved when the contact location is within a tolerance of .060 +/- .001.
- 6 Place bead onto neck portion of the tool. Thread Bead Assembly tool firmly into the coupling nut. Push the tool's plunger between your thumb and fingers to assemble the bead. Check bead location. Assemble seal ring onto body.

TOOL	145-0693-001/002 (FOR .086 SEMI-RIGID)	145-0694-001/002 (FOR .141 SEMI-RIGID)
Semi-Rigid Cable Vise	140-0000-962	140-0000-962
Vise Stop	140-0000-968	140-0000-968
Bead Assy. Tool	140-0000-957	140-0000-957
Contact Soldering Tool	140-0000-960	140-0000-961
Body Soldering Tool	140-0000-958	140-0000-959
Cable Clamp Insert	140-0000-964	140-0000-965

**Emerson Network Power Connectivity Solutions** is a global manufacturer of a broad line of connectivity products and services supporting wireline and wireless communications, data networking, test and measurement, military, medical, broadcast and industrial applications. Connectivity Solutions delivers custom-engineered products and solutions with best-in-class service and support and customer-focused offers such as quick-turn prototyping, samples and supply chain management.

#### OEM Cable Assemblies

Custom-designed solutions for Multiconductor, Flat Ribbon, Wire Harness, Coaxial, D-sub, SCSI and discrete assemblies. Design support, molding, polarizing, custom shielding and testing capabilities.



#### Telecom/Broadband Cable Assemblies

Custom solutions for the Telecom, Data and Broadband markets. Expert in 50 position telco cables, coax assemblies and analog filter products. Quick delivery capabilities.



#### CATV Components

Residential and multi-unit amplifiers, security terminators, and drop splitters and passives. Headend signal management products and fiber optic connectivity for headend and optical node applications and return path test equipment.



Connectivity Solutions



#### Precision Coaxial Connectors and Cable Assemblies

Subminiature, microminiature, miniature and standard connectors, and custom assemblies, including SMA, SMB, 40 GHz-capable SMK, MMCX, BNC and N Connectors. Custom designs and modifications of standard products.



#### Fiber Optic Cable Assemblies and Components

High performance multimode and single mode fiber patch cords, multi-fiber assemblies and attenuators. Solutions for the Storage Area Network and Enterprise computing markets and for ESCON<sup>®</sup>, optical FibreChannel, Infiniband and Parallel Optics applications.



#### Multi-purpose Connectivity and Structured Wiring

Commercial-grade connectors, including F Connectors, BNC and TNC. Structured wiring components, including CAT 5E/6 assemblies, patch panels, wallplates and tools for data communications installations. USB and SCSI cables, D-sub connectors, adapters and hardware.